

RoHS Compliant

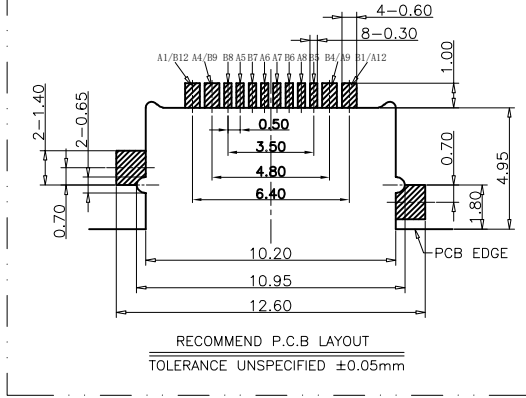
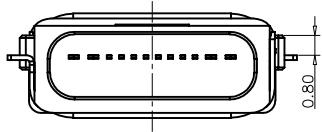
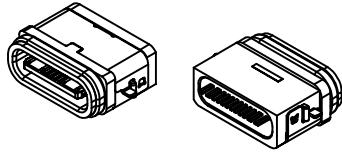

REVISIONS			
REV.	DESCRIPTION	DATE	DESIGN

NOTES:

SPECIFICATION:

- CURRENT RATING: 3.0 A
- VOLTAGE RATING: 3.0 V
- VBUS & GND PINS AND OTHER PINS: 40mΩ/PIN MAX
SHIELD: 50mΩ/MAX
LLCR MAX. CHANGE OF ALL PINS: 10Ωm
- INSULATION RESISTANCE: 100MΩ MIN
- DIELECTRIC WITHSTAND VOLTAGE, AC 100V FOR 1MINUTE
- INSERTION FORCE: 0.5~2.0kgf
- UNMATING FORCE: 0.8~2.0kgf
- DURABILITY: 10000 CYCLES
- OPERATING TEMPERATURE: -35°C~+85°C
- THE PEAK TEMPERATURE ON THE BOARD SHALL BE MAINTAINED FOR 10 SECONDS AT 210-230°C
- WATERPROOF: IP-X7.

USB TYPE C PIN ASSIGNMENTS

PIN NUMBER	SIGNAL NAME	PIN NUMBER	SIGNAL NAME
A1	GND	B12	GND
A4	VBUS	B9	VBUS
A5	CC1	B8	SBU2
A6	DP1	B7	DN1
A7	DN1	B6	DP2
A8	SBU1	B5	CC2
A9	VBUS	B4	VBUS
A12	GND	B1	GND

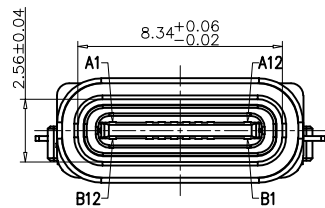
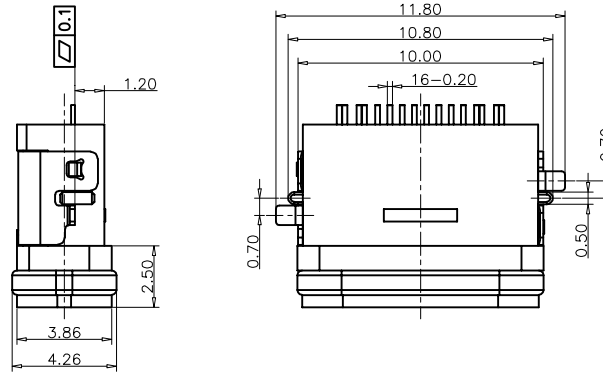
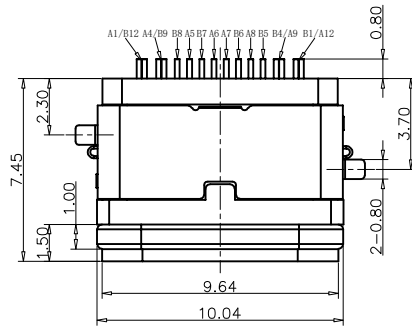

PART NO. INFORMATION

U06-C F X X 5 R - W015-V2

- PORT TYPE
C: TYPE C
- GENDER
F: FEMALE
M: MALE
- CONTACT PLATED
1: GOLD FLASH
2: GOLD 3U"
3: GOLD 5U"
4: GOLD 10U"
5: GOLD 15U"
6: GOLD 30U"
- PACKAGE
R: TAPE REEL
- HOUSING COLOR
2: WHITE
5: BLACK
9: NATURE
- HOUSING MATERIAL
A: LCP B: PBT
C: PA9T D: PA6T
E: PA46 F: PA66

TABLE:

NO	PART	Q'TY	Material
1	PLASTIC SHELL	1	LCP UL94 V-0 BLACK
2	CONTACT	16	C2680,TIN80u"/Au3u"/Ni30u"PLATED
3	MID PLATE	1	SUS301,NO PLATING
4	HOUSING	1	LCP UL94 V-0 BLACK
5	SHIELDING PLATE	1	SUS,NI PLATED
6	WATERPROOF RING	1	SILICONE UL94 V-0 RED

Bestcreate Technology Limited

TOLERANCES UNLESS OTHERWISE SPECIFIED:

.X	± 0.20	.X'	± 5'
.XX	± 0.15	.X''	± 2'
.XXX	± 0.10	.X'''	± 1'

Website: www.bsc-elec.com

Email: bestcreate@bsc-elec.com

DESIGN:
I. L

DATE:

CHECKED:
C. W

DATE:

APPROVED:
C. W

DATE:

TITLE:

IPX7 Waterproof USB TYPE C 16P FEMALE CONNECTOR
MID-MOUNT 1.2MM, L=7.45mm

MATERIAL:

PART NO:
U06-CFXX5R-W015-V2

SIZE:
A4

FINISH:

DWG NO:
U06-CFXX5R-W015-V2

REV:
A

UNIT
mm

SCALE
1=1

QUALITY
SYMBOLS

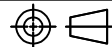

1

2

3

4

5

6

7

8